

Novice TTC2

Novice

TTC2 at NNE 490½ 278½ to TC4 at SW 518½ 221¾
via TC3
Standard sections – Coloured Roads Only

Go via the following tulips

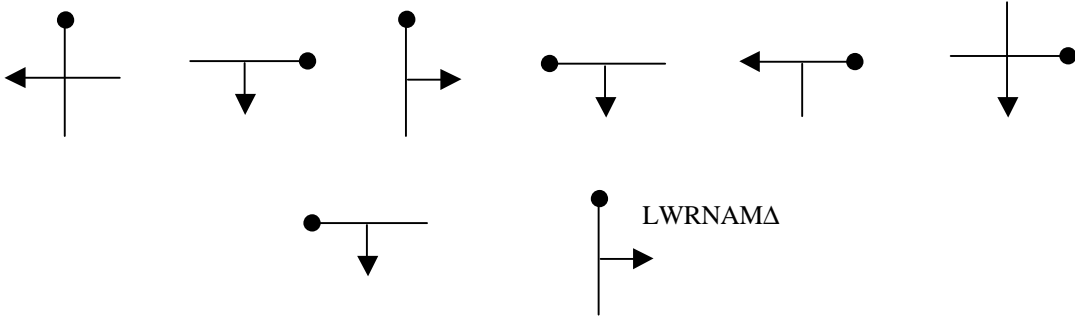

LWRNAMΔ = Long Way Round Not As Map Triangle (at the junction)

Novice TC4

Novice

TC4 at SW 518½ 221¾ to TC7a at NE 560½ 216½
via TC5 and TC6
Standard sections – Will Use Whites

Cross grid lines (instructions also given for some junctions)

TC4	52	23	GW TR	ML
53	23	22	GW LWRNAMΔ	54
22	55	TC5	55	23
24	55	25	56	TC6
25	GW	24	23	56
GW	22	56	TC7	56

TC7a and TC7b are at the same location and form a lateness recovery section of 5 minutes

GW = Give Way

TR = Turn Right

ML = Miss Left

LWRNAMΔ = Long Way Round Not As Map Triangle (at the junction)

TC = Time Control

Novice
TC7b

Novice

TC7b at NE $560\frac{1}{2}$ 216 $\frac{1}{2}$ to TC10 at SSW $594\frac{1}{4}$ 204 $\frac{1}{2}$
via TC8 and TC9
Standard sections – Coloured Roads Only

Cross the following gridlines and letters in order:

56 55 21 54 20 54 19 55 H o
19 56 57 20 n p t 58 59 21

Novice TC10

Novice

TC10 at SSW 594¼ 204½ to TC13 at SSW 597 268
via TC11 and TC12
Standard sections – Will Use Whites

Go via the following at junctions

MR (white)	TL	TR (GW)	MR (GW)	TL (missing white), LWR Trees, follow arrows
TR (missing white)	MR (white)	TR	TL (XR)	ML
MR	ML (white)	ML (white)	TR (onto white at XR)	TR
TL (GW)	MR (white)	TR	MR	TL (missing white)

MR = Miss Right
ML = Miss Left
TL = Turn Left
TR = Turn Right
XR = Cross Roads
GW = Give Way
LWR = Long Way Round

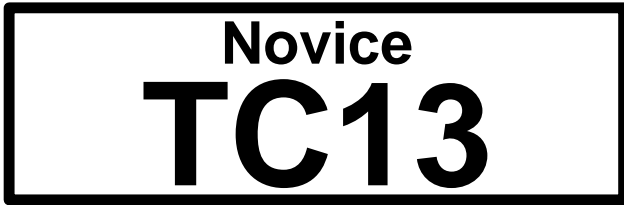

Novice

TC13 at SSW 597 268 to TC14 at SSW 626 275³/₄
Standard section – Coloured Roads Only

Cross the gridlines

27 60 GW 27 61 62 LΔ 26 LΔ 26 27 28

GW = Give Way

LΔ = Long Way Round Not As Map Triangle

Novice
TC14

Novice

TC14 at SSW 626 275¾ to TC16 at SSW 644¼ 251¾
via TC15
Standard sections – Coloured Roads Only

Go via the herringbone

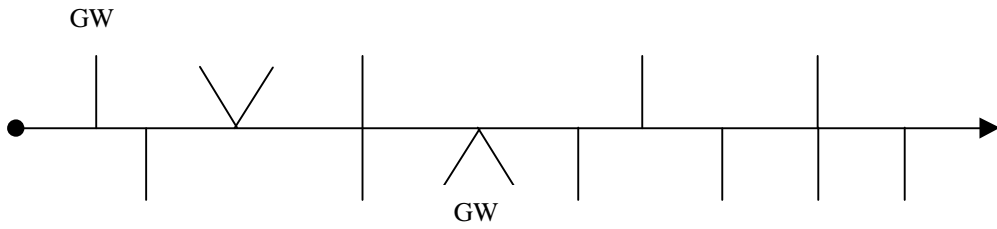

Novice
TC16

Novice

TC16 at SSW 644¹/₄ 251³/₄ to TC18a at ESE 663 194
via TC17
Standard sections – Coloured Roads Only

Depart junctions on these bearings:

192°

100°

095°

144°

155° (GW)

130°

276°

TC18a and TC18b are the same location and form a lateness recovery section of 5 minutes

Novice TC18b

Novice

TC18b at ESE 663 194 to TC20 at ESE 636 187¼
via TC19

TC18b to TC20 Standard sections – Coloured Roads Only

Go via:

E1 B3 D2 A2 C5 E4 C1 A4 B5 C3 D3

	1	2	3	4	5
A		GW 			L?
B					
C	L? 		GW 		
D			GW 		
E	L? 				

L? = Long Way Round Not As Map Triangle
GW = Give Way

Novice TC20

Novice

TC20 at ESE 636 187¼ to TC21 at ENE 578 188
Standard section – Coloured Roads Only

Go via:

MR SO(XR) ML ML MR SO(XR)

ML SO(5way, GW & LWRNAM?) Shepherds

MR = Miss Right

ML = Miss Left

SO = Straight On

XR = Cross Roads

5way = 5 way junction

GW = Give Way

LWRNAM? = Long Way Round Not As Map Triangle

Novice
MTC24

Novice

MTC24 at W 577³/₄ 080³/₄ to TC26 at E 626¹/₄ 082¹/₂
via TC25
Standard sections – Coloured Roads Only

Go via the tracing

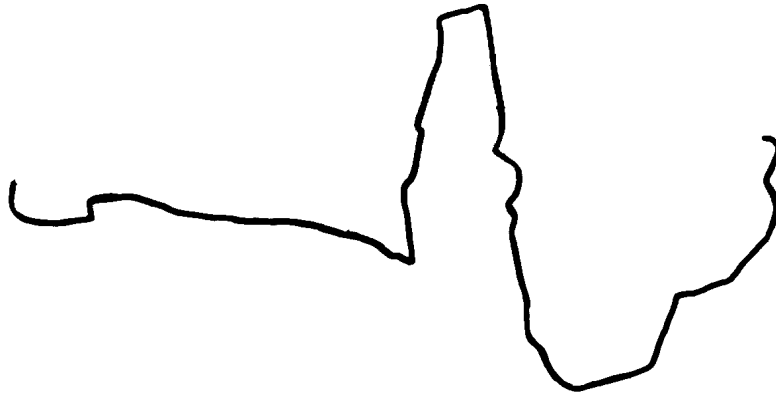

Give Way at 619069

Novice TC26

Novice

TC26 at E 626¼ 082½ to TC28 at WSW 618¾ 152¾
via TC27
Standard sections – Coloured Roads Only

At junctions:

ML (LWRNAMΔ, see diagram below)	TR	TL	TR
(LWRNAMΔ at next junction with a white)	TL	MR	TR
MR(GW), ML (staggered crossroads)	TL	TR(GW)	ML

MR = Miss Right / ML = Miss Left

TL = Turn Left / TR = Turn Right

GW = Give Way

LWRNAMΔ = Long Way Round Not As Map Triangle

Diagram of 1st LWRNAMΔ:

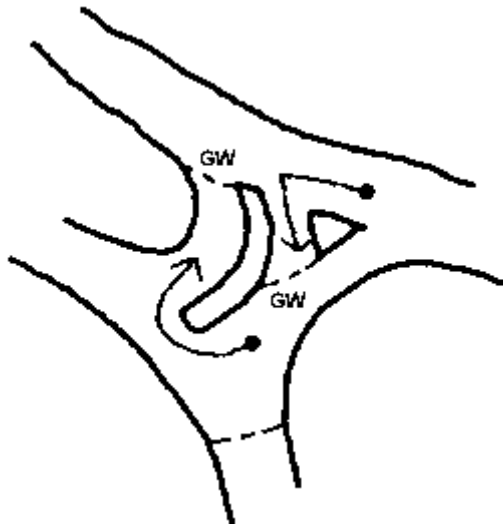

Novice TC28

Novice

TC28 at WSW 618¾ 152¾ to TC30 at SSW 666½ 133
via TC29

Standard sections – Coloured Roads Only

Go via grid lines and spot heights:

62	15	63	64
65	14	66	66
•57(GW)	13	66	LWRNAMΔ
13	LWRNAMΔ(GW)	(GW)	67

GW = Give Way

LWR NAMΔ = Long Way Round Not As Map Triangle

Novice TC30

Novice

TC30 at SSW 666½ 133 to TC32 at SW 691¾ 147
via TC31
Standard sections – Coloured Roads Only

Go via the herringbone

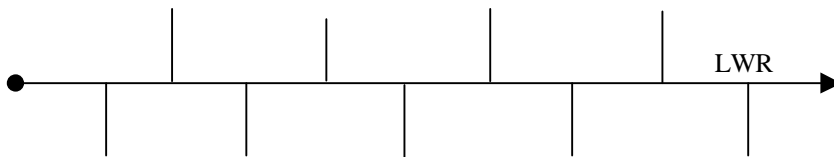

You will need the extra map sheet enclosed with this routecard
LWR = Long Way Round Not As Map Triangle

<p>Novice TC32</p>

Novice

TC32 at SW 691¾ 147 to TC34a at S 682 194
via TC33
Standard sections – Will Use Whites

Cross grid lines at the following headings

N	W	GW at next junction	NNE
NNE	W	WNW	NNE
N	N (on white)	ESE	SSE
LWRNAMΔ	LWR<u>AM</u>D	NW	

LWR NAMΔ = Long Way Round Not As Map Triangle

LWRAMD = Long Way Round **As Map** Triangle

See extra map sheet enclosed in the envelope for TC30

TC34a and TC34b are the same location and form a lateness recovery section of 10 minutes

Novice TC34b

Novice

TC34b at S 682 194 to TTC36 at S 676¼ 229
via TC35
TC34b to TC35 Standard section – Coloured Roads Only

Go via the following junctions, in order:



TC35 to TTC36 Transport Section – Coloured Roads Only

Take the shortest route to TTC36 at S 676½ 229

Please drive quietly – no lateness penalty applies to this section.

You will need the extra map sheet enclosed with this routecard



Novice

TTC36 at S 676¼ 229 to TC38 at WSW 694 264
via TC37
Standard sections – Coloured Roads Only

> ESE·98N < SW·169S(LWRNAMΔ) GW at next junction um (extra sheet given at TC34b) WSW·164

See extra map sheet enclosed in the envelope for TC34b

Novice TC38

Novice

TC38 at WSW 694 264 to TC39 at WSW 717 250½
Standard section – Coloured Roads Only

Go via •156 to TC39 at WSW 717 250½

Give Way at 2nd junction

Long Way Round as shown at the 3rd junction:

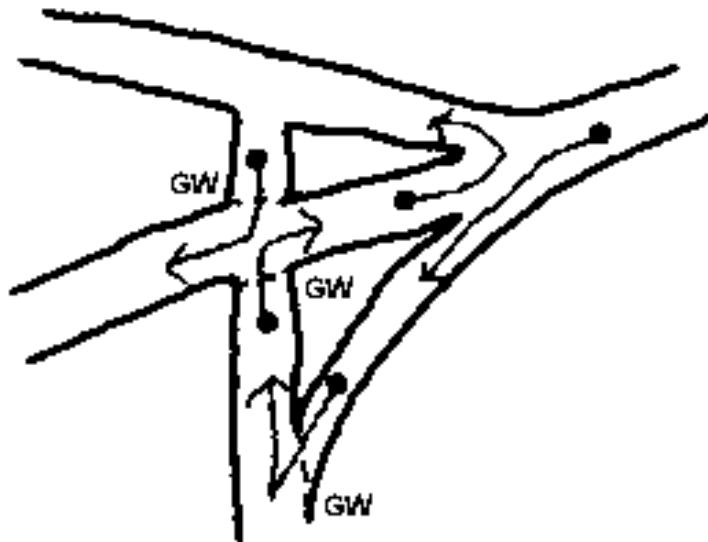

See extra map sheet enclosed in the envelope for TC34b

<p>Novice TC39</p>

Novice

TC39 at WSW 717 250½ to TC40 at W 709 276½
Standard sections – Coloured Roads Only

Go via Grid Squares and Give Ways

7125
Via GW at SE 715 257¼

7025

7026

7126

7026
GW at both XRs

7126

7127
Via GW at SW 716¼ 273¼

7027
Via GW at SSE 708¼ 276¼

7127

See extra map sheet enclosed in the envelope for TC34b

Novice TC40

Novice

TC40 at W 709 276½ to TC42 at SSE 668¼ 282¼
via TC41
Standard sections – Coloured Roads Only

Depart each junction on the following heading

NE	SSW(GW)	SW(LWRNAMΔ)	SSW(LWRNAMΔ)	SW(LWRNAMΔ)
WNW	ENE	NW(GW)	WSW	NW
SW	NNW			

See extra map sheet enclosed in the envelope for TC34b



Novice

TC42 at SSE 668¼ 282¼ to TC43 at WNW 678 293
Standard sections – Coloured Roads Only

Distance to the next junction

1000m 825m 800m 800m

GW at:
3rd junction

LWRNAMΔ at:
1st and 3rd junctions

Novice
TC44

Novice

TC44 at S 665 323 to TC46 at ENE 626¾ 340½
via TC45
Standard sections – Coloured Roads Only

10ths of a Grid Square where the route crosses

5½

8¾

2

Avoid: ·115
Go via: t r o r

4¾

9¼

9

GW at:

1st, 3rd and 4th junctions

Novice TC46

Novice

TC46 at ENE 626¾ 340½ to MTC48 at ENE 592 353¾
via TC47
TC46 to TC47 Standard section – Coloured Roads Only

Depart grid squares:

W E N E N N

TC47 to MTC48 Standard section – Coloured Roads Only

It's the last section – so just drive!

(shortest route to MTC48 at ENE 592 353¾)

Hope you've enjoyed it.

From MTC48 Proceed **Non-Competitive** to Finish / breakfast

Turn Right onto the B3046

Turn Left onto yellow at Northington in GS 5637

Turn Right onto A33 in GS 5136

Turn Left onto yellow in GS 5237

To the Half Moon and Spread Eagle at 516¾4389

Please park quietly / sensibly (the field may be used dependent on weather conditions)